

DN400

DN	H1	H2	H3	L	A	PN10	
						C	n-ø
DN200	177	260	36	64	22.2	295	12-23
DN250	203	292	36	70	28.6	350	12-23
DN300	242	337	36	80	31.8	400	12-23
DN400	298	400	51	90	33.3	515	16-23

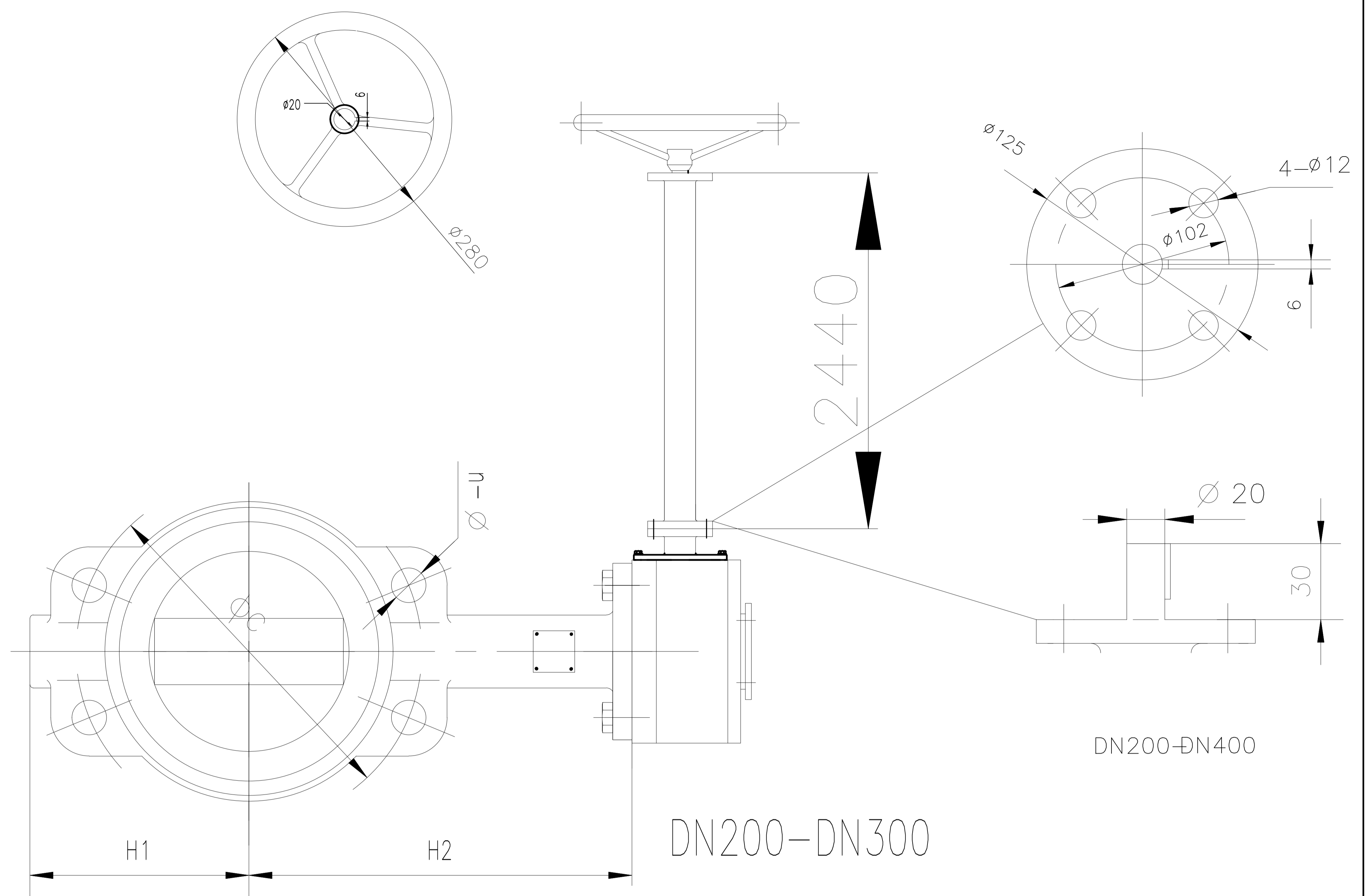

6	O-RING	EPDM	1
5	BUSHING	PTFE	4
4	STEM	SS410	1
3	SEAT	EPDM	1
2	DISC	CF8	1
1	BODY	DI GGG50	1
NO.	PARTS NAME	MATERIAL	QTY

VALVE WORKING PRESSURE: : PN10

TEST	PRESSURE	SHELL	SEAL
	HYDROSTATIC	15 kg/cm ²	11. kg/cm ²
STAND-ARD	AIR		
	DESIGN CODE	DI N3202	
	INSPECTION & TEST	API 598	
	END STANDARD	EN1092-2 PN10	
	FACE TO FACE	DI N3202	

WAFER TYPE BUTTERFLY VALVE

QI NGDAO JUDBERD MACHI NERY CO., LTD