

② CS OR SS NUT (DAROMET THICKNESS 8-10UM, HOT DIP GALVANIZATION 30-40UM, TEFLON COATING)

③ CS OR SS WASHER (DAROMET THICKNESS 8-10UM, HOT DIP GALVANIZATION 30-40UM, TEFLON COATING)

④ EPDM GASKET ACCORDING TO EN681-1, SBR, NBR CAN BE APPLICABLE

⑧ CS OR SS CARRIAGE BOLTS (DAROMET THICKNESS 8-10UM, HOT DIP GALVANIZATION 30-40UM, TEFLON COATING)

① PLASTIC CAP (PROTECT BOLTS THREAD)

⑤ BRASS GRIP RING CW617N

⑥ DUCTILE IRON BODY ACCORDING TO EN1563

⑦ DUCTILE IRON END RINGS ACCORDING TO EN1563

**PRECAUTIONS**

THIS RESTRAINED FLANGE ADAPTOR IS DESIGNED FOR HDPE PIPE. WITH GRIP RINGS TO AVOID PIPES TO BE PULLED OUT, PIPE STIFFENERS ARE RECOMMENDED TO BE USED

**SEE PAGE 2 FOR TECHNICAL SPECIFICATIONS.**

UNLESS OTHERWISE SPECIFIED: DIMENSIONS ARE IN MILLIMETERS		FINISH:		DEBUR AND BREAK SHARP EDGES		DO NOT SCALE DRAWING		REVISION	
SURFACE FINISH:									
TOLERANCES:									
LINEAR:									
ANGULAR:									
DRAWN		NAME		SIGNATURE		DATE		TITLE:	
CHK'D								<b>RESTRAINED COUPLING FOR HDPE</b>	
APP'VD								MANUFACTURER	
MFG								QINGDAO JUDBERD MACHINERY CO LTD	
Q.A						MATERIAL:		SCALE:	
								SHEET 2 OF 2	
						WEIGHT:			

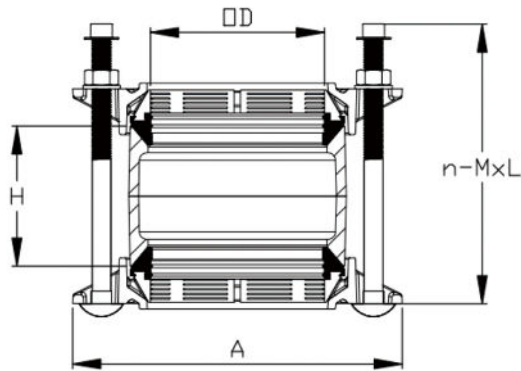

SECTION A-A

NOMINAL DIAMETER	HDPE PIPE OUTSIDE DIAMETER	END RINGS OUTSIDE DIAMETER	CENTER SLEEVE HEIGHT	BOLTS NO-BOLTS SIZE/BOLTS LENGTH	BOLTS TYPE	MAX PRESSURE (BAR)	MAX DEFLECTION (DEGREES)	APPX.WEIGHT (KGS)
DN	OD	A	H	n-MxL				
DN50	63	153	95	2-M12x180	CARRIAGE BOLTS	25	±3°	3.1
DN60/65	75	166	95	2-M12x180	CARRIAGE BOLTS	25	±3°	3.6
DN80	90	193	95	4-M12x180	CARRIAGE BOLTS	25	±3°	4.6
DN100	110	215	95	4-M12x180	CARRIAGE BOLTS	25	±3°	4.9
DN125	125	230	95	4-M12x180	CARRIAGE BOLTS	25	±3°	5.8
DN125	140	241	95	4-M12x180	CARRIAGE BOLTS	25	±3°	6.7
DN150	160	265	95	4-M12x180	CARRIAGE BOLTS	25	±3°	7.9
DN150	180	275	95	4-M12x180	CARRIAGE BOLTS	25	±3°	8.8
DN200	200	306	125	4-M12x210	CARRIAGE BOLTS	25	±3°	10.3
DN200	225	320	125	4-M12x210	CARRIAGE BOLTS	25	±3°	11.0
DN250	250	357	125	6-M12x210	CARRIAGE BOLTS	25	±3°	13.9
DN250	280	374	125	6-M12x210	CARRIAGE BOLTS	25	±3°	14.5
DN300	315	422	125	6-M12x230	CARRIAGE BOLTS	25	±3°	19.2

**NOTE**

DATA SUCH AS THE ABOVE IS BASED ON OUR MOST ACCURATE AT THE TIME OF OUR RELEASE, BUT WE MAY MAKE UPDATES OR IMPROVEMENTS TO OUR PRODUCTS, SO IF YOU NEED THE LATEST, PLEASE CONTACT US.

UNLESS OTHERWISE SPECIFIED: DIMENSIONS ARE IN MILLIMETERS				FINISH:		DEBUR AND BREAK SHARP EDGES		DO NOT SCALE DRAWING		REVISION	
SURFACE FINISH:											
TOLERANCES:											
LINEAR:											
ANGULAR:											
NAME		SIGNATURE		DATE						TITLE:	
DRAWN										<b>RESTRAINED COUPLING FOR HDPE</b>	
CHK'D											
APP'VD											
MFG										MANUFACTURER	
Q.A						MATERIAL:				QINGDAO JUDBERD MACHINERY CO LTD	
						WEIGHT:				SCALE:	
										SHEET 2 OF 2	