

JUDBERD MACHINERY



RESTRAINED FLANGE ADAPTOR

RESTRAINED FLANGE ADAPTOR

RESTRAINED TYPE FOR HDPE PIPE(OD≤315)

FOR BIGGER SIZE,
PLEASE REFERE TO OUR MECHANICAL JOINT
FLANGE ADAPTER SERIES NO. FA009



2 YEARS
WARRANTY



30 YEARS
EXPERIENCE

● CERTIFIED TO WRAS AND ACS



FEATURE



ONLY ACCOMMODATES TO HDPE PIPE, DESIGNED ACCORDING TO HDPE PIPE CHARACTERISTICS AND DIMENSIONS, GOOD SEALING



CASTINGS ARE PRODUCED BY AUTO MOLDELLING LINE,THE SURFACE OF THE CASTING IS SMOOTHER BECAUSE THE MECHANICAL MANUFACTURE COMPACTS IT MORE TIGHTLY. MORE EFFICIENT, SO LOWER COSTS AND FASTER DELIVERY TIMES.



RAPID INSTALLATION



CHINA MANUFACTURER DIRECTLY SALE



SEGMENT DESIGN GRIP RING ALLOWS FOR SOME PIPE OVALISATIONTHE BARBED DESIGN OF THE GRIP RING ENHANCES GRIP AS THE PIPE MOVES.



PIPE STIFFENERS CAN EFFECTIVELY PREVENT THE DEFORMATION OF HDPE PIPE AND PREVENT THE OVAL OF PIPE

NOTE

DATA SUCH AS THE ABOVE IS BASED ON OUR MOST ACCURATE AT THE TIME OF OUR RELEASE, BUT WE MAY MAKE UPDATES OR IMPROVEMENTS TO OUR PRODUCTS, SO IF YOU NEED THE LATEST, PLEASE CONTACT US.

JUDBERD MACHINERY



RESTRAINED FLANGE ADAPTOR

RESTRAINED FLANGE ADAPTOR

DATA SHEET

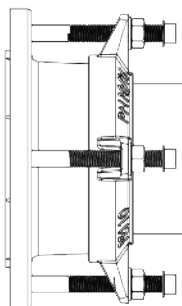
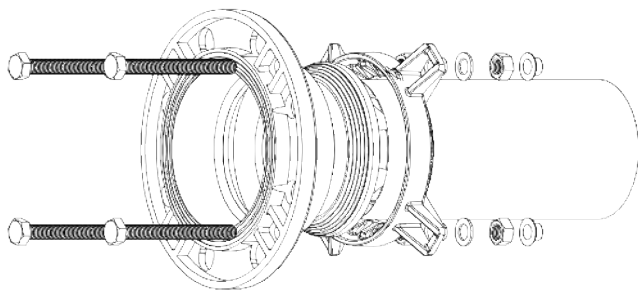
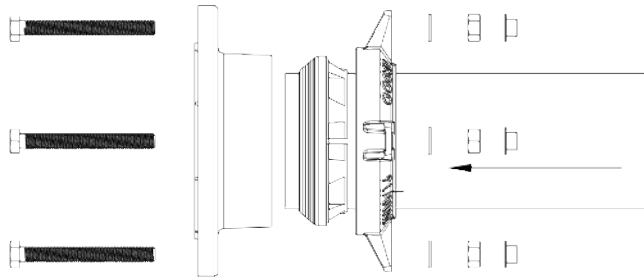

HIGH DENSITY POLYETHYLENE PIPE,
ABBREVIATED AS HDPE PIPE

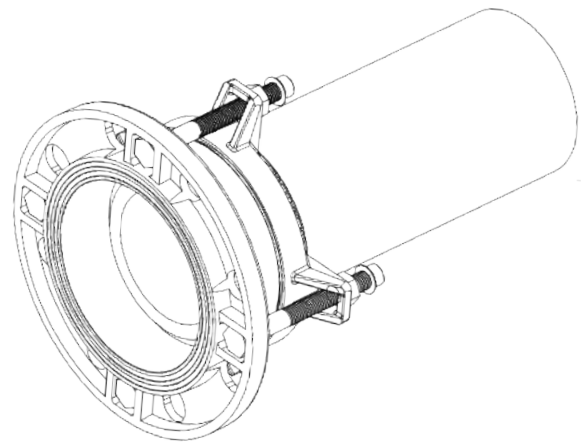

FLANGE SIZE/PIPE OUTSIDE DIAMETER	MUXIMUM ALLOWABLE PIPE INSERTION LENGTH	ALLOWABLE PIPE OVAL	ALLOWABLE PIPE OD TOLERANCE
DN/OD			
FROM DN50/OD63 TO DN150/OD180	50-90	2	±1
FROM DN200/OD200 TO DN250/OD280	50-100	2	±1
DN300/OD315	50-110	2	±1

- Standard flange on restrained flange adaptor is EN1092-2.ANSI B 16.5/ANSI B 16.47 and AS/NZS4087 are available as an option.

NOTE

DATA SUCH AS THE ABOVE IS BASED ON OUR MOST ACCURATE AT THE TIME OF OUR RELEASE, BUT WE MAY MAKE UPDATES OR IMPROVEMENTS TO OUR PRODUCTS, SO IF YOU NEED THE LATEST, PLEASE CONTACT US.