



JUDBERD MACHINERY

LIGHT DUTY RIGID DUCTILE IRON DISMANTLING JOINT Series No. DJ004

RIGID TYPE FROM DN40 TO DN1200 PN10/PN16

THE MAXIMUM SIZE FOR LIGHT DUTY DISMANTLING JOINT IS DN1200 PN10/16, FOR BIGGER SIZE, WE SUGGEST YOU USE HEAVY DUTY TYPE DJ001 AS BELOW



2 YEARS/5 YEARS/10 YEARS WARRANTY ACCORDING TO DIFFERENT MATERIAL CHOICE



30 YEARS EXPERIENCE

FEATURE

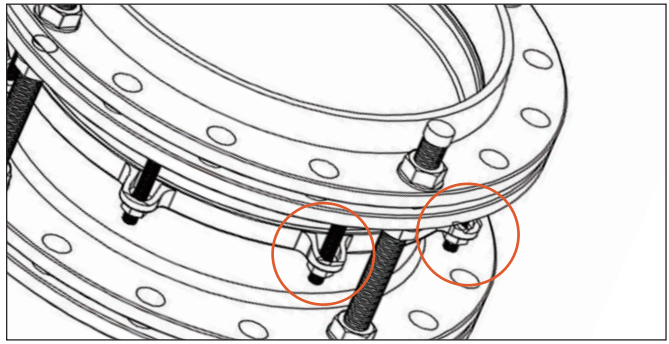

① GOOD SEALING CAN BE ACHIEVED BY TIGHTENING SEPARATE SMALL BOLTS, NOT AFFECTED BY THE AXIAL FORCE OF THE PIPELINE.

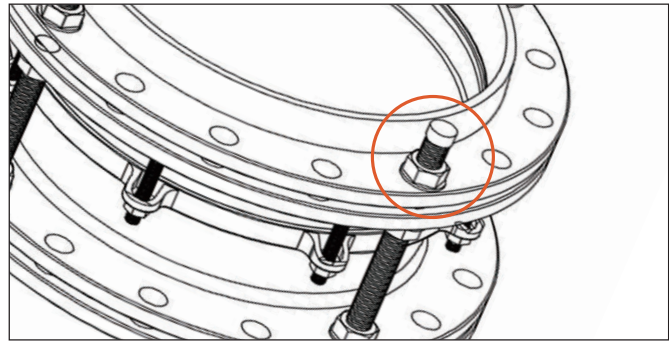

② ONLY 25% QUANTITY (NO LESS THAN 4 PCS) LONG TIE RODS ARE NEEDED, SHORT INSTALLATION TIME AND LOW COST.

● DESIGN OPTION

