

**WASHER AS PER DIN125,  
 CARBON STEEL GRADE 4.8/6.8/8.8  
 WITH DACROMET  
 THICKNESS 8-10UM/HOT  
 DIP GALVANIZATION  
 30-40UM/STAINLESS STEEL  
 A2/A4 OR AS PER  
 CLIENT REQUIREMENT**

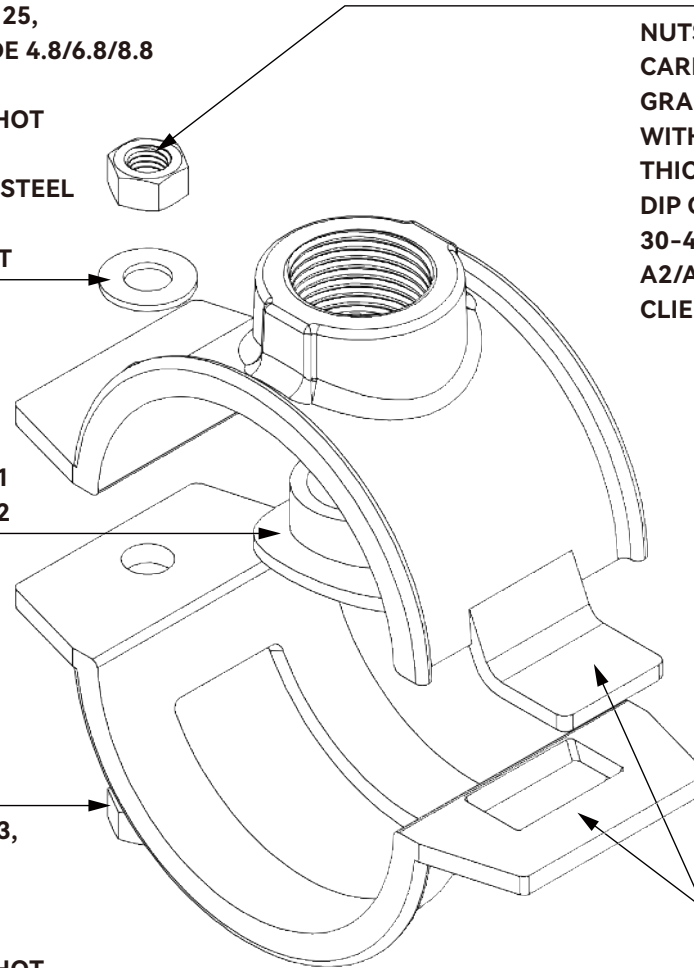

**NUTS AS PER DIN934,  
 CARBON STEEL  
 GRADE 4.8/6.8/8.8  
 WITH DACROMET  
 THICKNESS 8-10UM/HOT  
 DIP GALVANIZATION  
 30-40UM/STAINLESS STEEL  
 A2/A4 OR AS PER  
 CLIENT REQUIREMENT**

**GASKET  
 EPDM AS PER EN681-1  
 OR NBR AS PER EN682**



**BOLTS AS PER DIN 933,  
 CARBON STEEL  
 GRADE 4.8/6.8/8.8  
 WITH DACROMET  
 THICKNESS 8-10UM/HOT  
 DIP GALVANIZATION  
 30-40UM/STAINLESS STEEL  
 A2/A4 OR AS PER CLIENT  
 REQUIREMENT**

**BODY  
 DUCTILE IRON EN  
 GJS450-10 AS PER  
 EN1563 OR OTHERS  
 AS PER CLIENT  
 REQUIREMENT**

**PRECAUTIONS**

- 1, Suitable for PE and PVC pipes.
- 2, Sealing is achieved by compressing the EPDM gasket against the bottom of the isolation valve. The opening and closing of the branch pipeline are controlled by isolation valve.
- 3, Medium conveyed can be water, oil or gas.

UNLESS OTHERWISE SPECIFIED: DIMENSIONS ARE IN MILLIMETERS				FINISH:		DEBUR AND BREAK SHARP EDGES		DO NOT SCALE DRAWING		REVISION	
SURFACE FINISH:											
TOLERANCES:											
LINEAR:											
LINEAR:											
ANGULAR:											
DRAWN		SIGNATURE		DATE						TITLE:	
CHK'D										<b>DI SADDLE CLAMP FOR PVC AND HDPE PIPE</b>	
APP'VD										MANUFACTURER	
MFG										QINGDAO JUDBERD MACHINERY CO LTD	
Q.A						MATERIAL:				SCALE:	
										SHEET 1 OF 1	
						WEIGHT:					

