

JUDBERD MACHINERY



TAPPING SADDLE WITH THREAD OUTLET -SINGLE BAND/DOUBLE BAND/MULTIPLE BANDS STYLE TSTO

SADDLE CLAMP ,WIDE RANGE TYPE ,DESIGNED FOR VARIOUS PIPES (DUCTILE IRON PIPE,STEEL PIPE,GRP PIPE,AC PIPE,PVC PIPE,PE PIPE ETC) WHICH PIPE OUTSIDE DIAMETER IS IN OUR RANGE. THREAD OUTLET FROM DN50 TO DN400 PN10/16

BIGGER SIZE AND HIGHER PRESSURE ARE ALSO AVAILABLE, PLEASE CONSULT JUDBERD.



2 YEARS WARRANTY
ACCORDING TO DIFFERENT MATERIAL CHOICE



30 YEARS EXPERIENCE

● CERTIFIED TO WRAS AND ACS

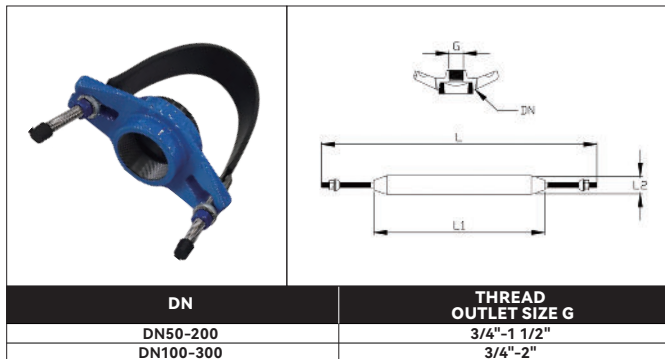

PIPE Outside Diameter Range(mm)	L2	L1	L
60-77	40/60	160	350
77-95	40/60	200	390
98-119	40/60	270	460
102-122	40/60	275	465
120-150	40/60	332	562
139-160	40/60	368	558
150-180	40/60	392	622
170-195	40/60	450	640
200-230	40/60	530	760
230-250	40/60	610	800
250-280	40/60	675	905
285-315	40/60	770	1000
315-340	40/60	860	1050

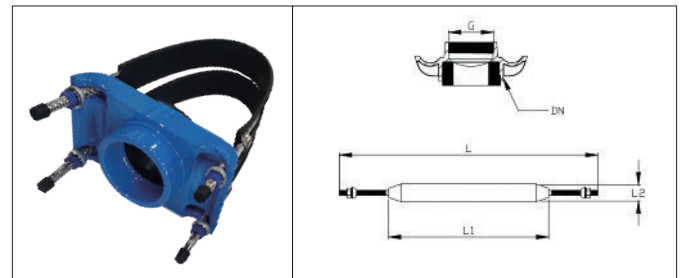

DN	THREAD OUTLET SIZE G	PIPE Outside Diameter Range(mm)	L2	L1	L
DN150-400	2"-3"	170-195	40/60	450	640
	2"-3"	200-230	40/60	530	760
	2"-3"	230-250	40/60	610	800
	2"-3"	250-280	40/60	675	905
	2"-3"	285-315	40/60	770	1000
	2"-3"	315-340	40/60	860	1060
	2"-3"	355-380	40/60	965	1165
	2"-3"	385-410	40/60	1060	1260
	2"-3"	410-435	40/60	1135	1335

Note Other thread outlet size G and pipe outside diameter range is also available upon requirement, but please note the range gap (max. pipe outside diameter - min pipe outside diameter for one tapping saddle) can't be very large because the bolts will interfering with each other.

- 1,Outlet thread must be sealing thread such as BSP, NPT, or CC. Threads without a sealing function (e.g., metric threads) are not suitable.
- 2,The standard length for sealing threads is typically 20mm. If customers have special requirements, we can extend the length.
- 3,In addition to the outlet sizes listed in the table above, we can also provide larger outlet sizes.

JUDBERD MACHINERY



TAPPING SADDLE WITH THREAD OUTLET
-SINGLE BAND/DOUBLE BAND/MULTIPLE BANDS STYLE TSTO

STRIPS CAN BE CUSTOMIZED ACCORDING TO CLIENT REQUIREMENTS.

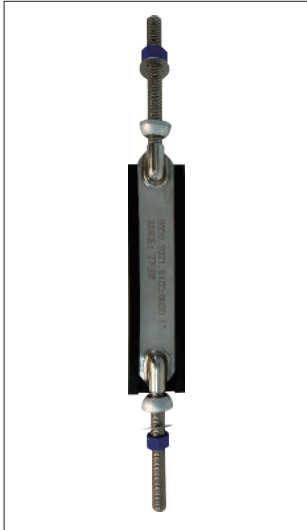

① Normal Design



② Design semi-spherical washer according to client requirement



③ Nylon semi-spherical washer according to client requirement



④ Special design strips for HDPE and PVC plastic pipe

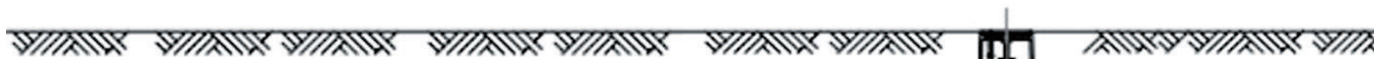

Isolation valve can be any valve with a shut-off function, such as a gate valve, ball valve, or service valve. However, it is essential to ensure that the male threads on the valve match the standard of the female threads on the outlet of the saddle clamp and that the threads have a sealing function.

The key dimensions of a saddle clamp consist of two parts:
1st is the material and outer diameter of the main pipe (as shown in Figure 1),
2nd is the standard and size of the threaded outlet for the branch (as shown in Figure 2).

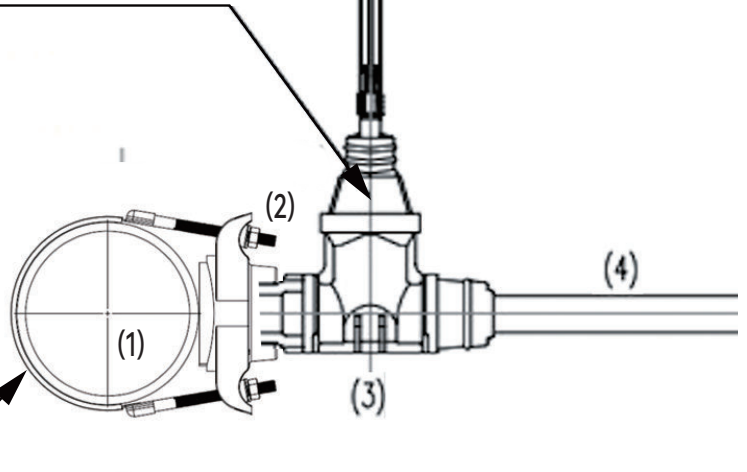

TAPPING SADDLE WITH THREAD OUTLET
-SINGLE BAND/DOUBLE BAND/
MULTIPLE BANDS STYLE TSTO