

**WASHER AS PER DIN125,
 CARBON STEEL
 GRADE 4.8/6.8/8.8
 WITH DACROMET
 THICKNESS 8-10UM/HOT
 DIP GALVANIZATION
 30-40UM/STAINLESS STEEL
 A2/A4 OR AS PER
 CLIENT REQUIREMENT**

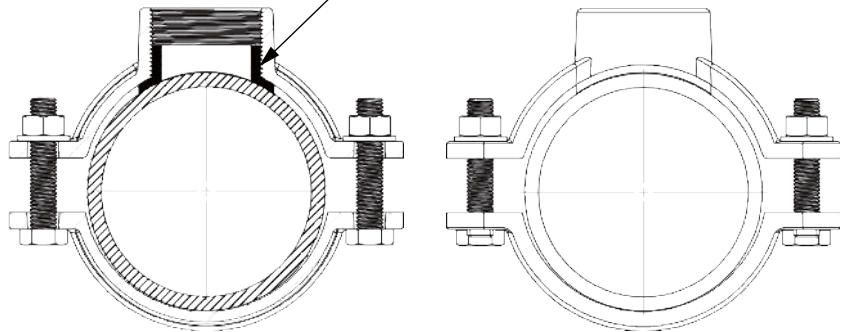

**NUTS AS PER DIN934,
 CARBON STEEL
 GRADE 4.8/6.8/8.8
 WITH DACROMET
 THICKNESS 8-10UM/HOT
 DIP GALVANIZATION
 30-40UM/STAINLESS STEEL
 A2/A4 OR AS PER
 CLIENT REQUIREMENT**

**GASKET
 EPDM AS PER EN681-1
 OR NBR AS PER EN682**



**BOLTS AS PER DIN 933,
 CARBON STEEL
 GRADE 4.8/6.8/8.8
 WITH DACROMET
 THICKNESS 8-10UM/HOT
 DIP GALVANIZATION
 30-40UM/STAINLESS STEEL
 A2/A4 OR AS PER CLIENT
 REQUIREMENT**

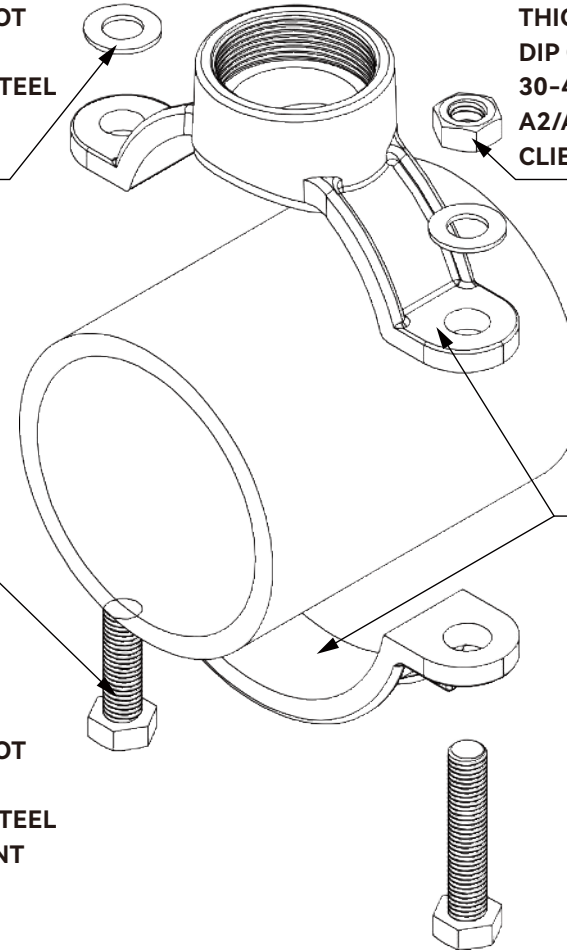

**BODY
 DUCTILE IRON
 EN GJS450-10
 AS PER EN1563 OR
 OTHERS AS PER
 CLIENT REQUIREMENT**

PRECAUTIONS

- 1, WIDE RANGE DESIGN: Suitable for various types of pipes, reducing inventory. However, it is not compatible with HDPE and PVC pipes.
- 2, Sealing is achieved by tightening the threads between its own female threads and male thread of isolation valve. The opening and closing of the branch pipeline are controlled by isolation valve.
- 3, MEDIUM CONVEYED CAN BE WATER, OIL, OR GAS.

UNLESS OTHERWISE SPECIFIED, DIMENSIONS ARE IN MILLIMETERS		FINISH:		DEBUR AND BREAK SHARP EDGES		DO NOT SCALE DRAWING		REVISION	
SURFACE FINISH:									
TOLERANCES:									
LINEAR:									
LINEAR:									
ANGULAR:									
DRAWN	NAME	SIGNATURE	DATE			TITLE: WIDE RANGE SADDLE CLAMP			
CHK'D									
APP'VD									
MFG									
Q.A					MATERIAL:	MANUFACTURER QINGDAO JUDBERD MACHINERY CO LTD			
					WEIGHT:	SCALE:		SHEET 1 OF 1	

