

**BOLTS AS PER DIN 933,  
 CARBON STEEL GRADE 4.8/6.8/8.8  
 WITH DACROMET THICKNESS 8-10UM/HOT  
 DIP GALVANIZATION  
 30-40UM/STAINLESS STEEL  
 A2/A4 OR AS PER CLIENT REQUIREMENT**

**WASHER AS PER DIN125,  
 CARBON STEEL GRADE  
 4.8/6.8/8.8 WITH DACROMET  
 THICKNESS 8-10UM/HOT  
 DIP GALVANIZATION  
 30-40UM/STAINLESS STEEL  
 A2/A4 OR AS PER CLIENT  
 REQUIREMENT**

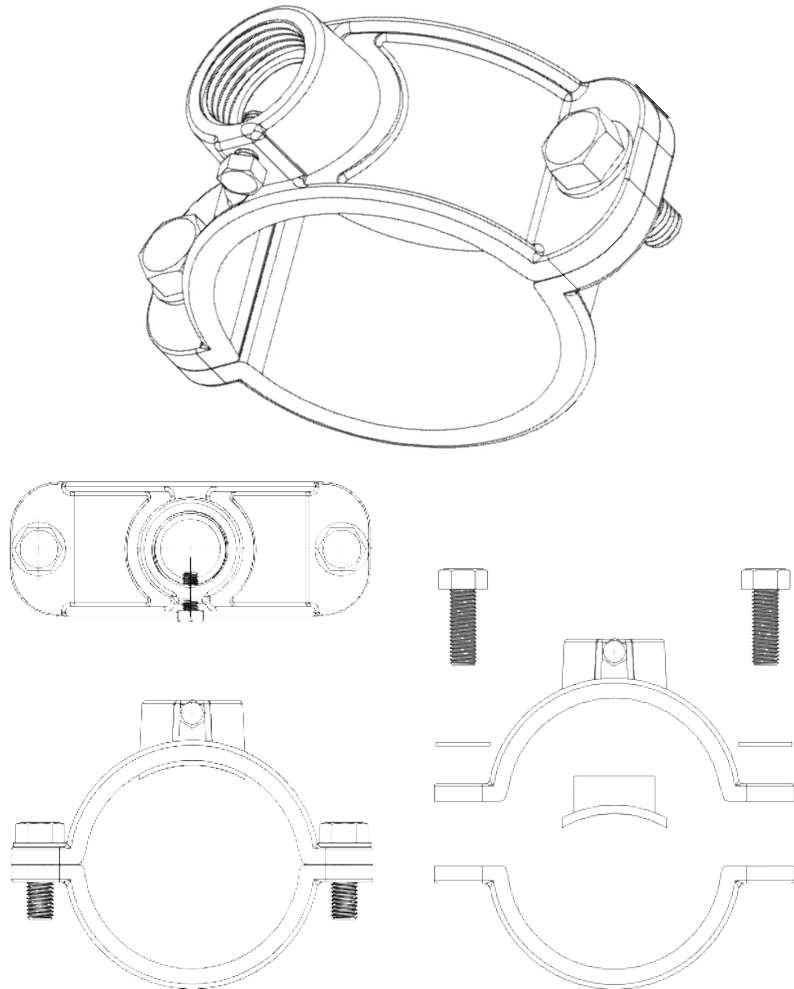

**BOLTS AS PER DIN 933,  
 CARBON STEEL  
 GRADE 4.8/6.8/8.8  
 WITH DACROMET  
 THICKNESS 8-10UM/HOT  
 DIP GALVANIZATION  
 30-40UM/STAINLESS STEEL  
 A2/A4 OR AS PER CLIENT  
 REQUIREMENT**

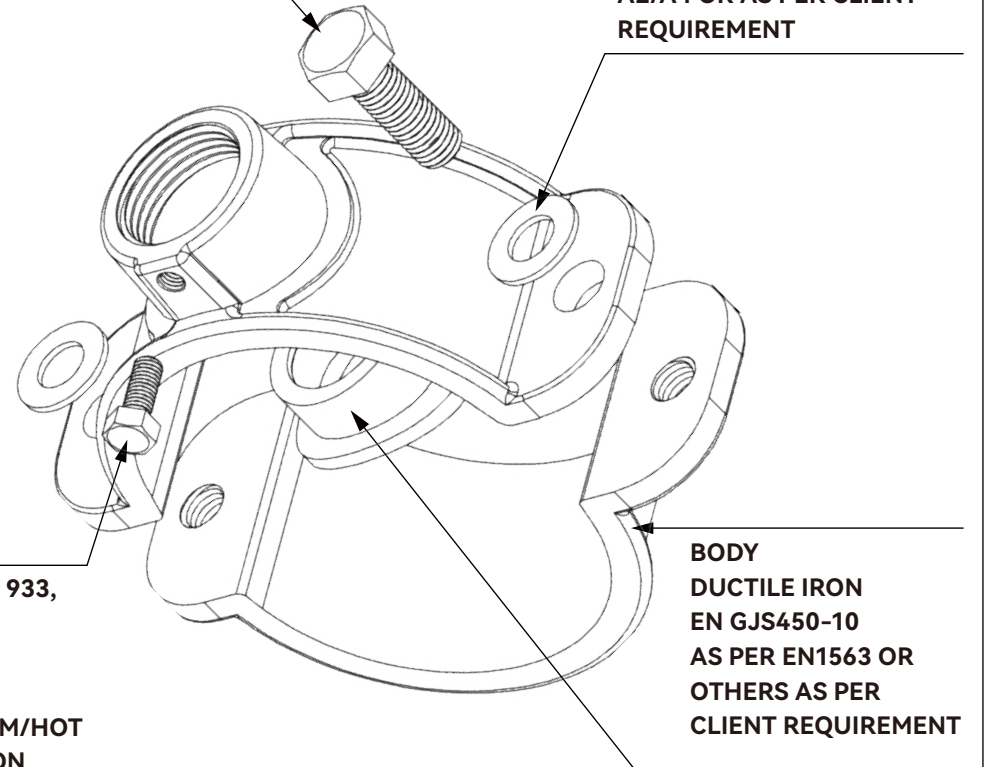

**BODY  
 DUCTILE IRON  
 EN GJS450-10  
 AS PER EN1563 OR  
 OTHERS AS PER  
 CLIENT REQUIREMENT**

**GASKET  
 EPDM AS PER EN681-1  
 OR NBR AS PER EN682**

<p><b>SUPPORT PTFE</b></p>	<p><b>PRECAUTIONS</b></p>	<p>UNLESS OTHERWISE SPECIFIED:                  DIMENSIONS ARE IN MILLIMETERS                  SURFACE FINISH:                  TOLERANCES:                  LINEAR:                  LINEAR:                  ANGULAR:</p>	<p>FINISH:</p>	<p>DEBUR AND                  BREAK SHARP                  EDGES</p>	<p>DO NOT SCALE DRAWING</p>	<p>REVISION</p>																																															
	<p>1, Suitable for PE and PVC pipes.                  2, Sealing is achieved by compressing the EPDM gasket supported by PTFE against the bottom of the isolation valve. The opening and closing of the branch pipeline are controlled by isolation valve.                  3, Medium conveyed can be water ,oil or gas.</p>	<table border="1"> <tr> <td>NAME</td> <td>SIGNATURE</td> <td>DATE</td> <td></td> <td></td> <td></td> </tr> <tr> <td>DRAWN</td> <td></td> <td></td> <td></td> <td></td> <td></td> </tr> <tr> <td>CHK'D</td> <td></td> <td></td> <td></td> <td></td> <td></td> </tr> <tr> <td>APP'VD</td> <td></td> <td></td> <td></td> <td></td> <td></td> </tr> <tr> <td>MFG</td> <td></td> <td></td> <td></td> <td></td> <td></td> </tr> <tr> <td>Q.A</td> <td></td> <td></td> <td></td> <td></td> <td></td> </tr> <tr> <td colspan="3">MATERIAL:</td> <td></td> <td></td> <td></td> </tr> <tr> <td colspan="3">WEIGHT:</td> <td></td> <td></td> <td></td> </tr> </table>	NAME	SIGNATURE	DATE				DRAWN						CHK'D						APP'VD						MFG						Q.A						MATERIAL:						WEIGHT:						<p>TITLE:  <b>SADDLE CLAMP FOR PE AND PVC                  PIPE WITH METRIC THREAD</b></p>	<p>MANUFACTURER                  QINGDAO JUDBERD MACHINERY CO LTD</p>	<p>SCALE: SHEET 1 OF 1</p>
NAME	SIGNATURE	DATE																																																			
DRAWN																																																					
CHK'D																																																					
APP'VD																																																					
MFG																																																					
Q.A																																																					
MATERIAL:																																																					
WEIGHT:																																																					

