

GASKET
 EPDM AS PER EN681-1
 OR NBR AS PER EN682

**STAINLESS STEEL BAND
 AND BOLT**

BODY
 DUCTILE IRON EN GJS450-10
 AS PER EN1563 OR
 OTHERS AS PER CLIENT REQUIREMENT

**EPDM PROTECTION COVER
 FOR PIPE**

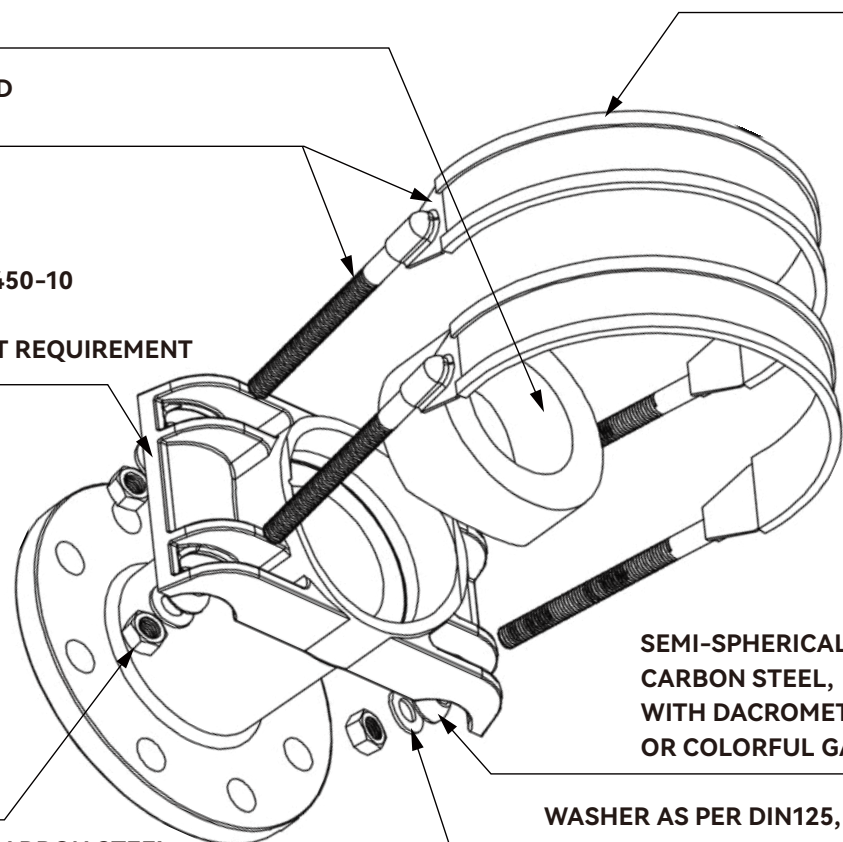

**SEMI-SPHERICAL WASHER,
 CARBON STEEL,
 WITH DACROMET COATING
 OR COLORFUL GALVANIZATION.**

**NUTS AS PER DIN934,CARBON STEEL
 GRADE 4.8/6.8/8.8 WITH DACROMET
 THICKNESS 8-10UM/HOT
 DIP GALVANIZATION
 30-40UM/STAINLESS STEEL
 A2/A4 OR AS PER CLIENT REQUIREMENT**

**WASHER AS PER DIN125,
 CARBON STEEL GRADE 4.8/6.8/8.8
 WITH DACROMET
 THICKNESS 8-10UM/HOT
 DIP GALVANIZATION
 30-40UM/STAINLESS STEEL
 A2/A4 OR AS PER CLIENT REQUIREMENT**

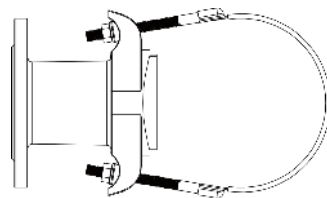
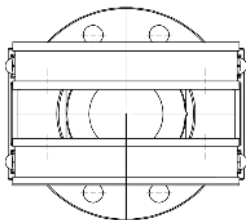

UNLESS OTHERWISE SPECIFIED, DIMENSIONS ARE IN MILLIMETERS				FINISH:		DEBUR AND BREAK SHARP EDGES		DO NOT SCALE DRAWING		REVISION	
SURFACE FINISH:											
TOLERANCES:											
LINEAR:											
LINEAR:											
ANGULAR:											
DRAWN		SIGNATURE		DATE						TITLE:	
CHK'D										TAPPING SADDLE FLANGE OUTLET -DOUBLE STRAPS/MULTIPLE STRAPS	
APP'VD										MANUFACTURER	
MFG										QINGDAO JUDBERD MACHINERY CO LTD	
Q.A						MATERIAL:					
						WEIGHT:				SCALE:	
										SHEET 1 OF 1	

