

JUDBERD MACHINERY



WIDE RANGE SADDLE CLAMP STYLE WRSC 001

WIDE RANGE SADDLE CLAMP STYLE WRSC 001

WIDE RANGE TYPE FROM DN80 TO DN300 PN10/16

BIGGER SIZE AND HIGHER PRESSURE ARE ALSO AVAILABLE, PLEASE CONSULT JUDBERD.



2 YEARS/5 YEARS/10 YEARS WARRANTY ACCORDING TO DIFFERENT MATERIAL CHOICE



30 YEARS EXPERIENCE

CERTIFIED TO WRAS AND ACS



JUDBERD MACHINERY

WIDE RANGE SADDLE CLAMP STYLE WRSC 001

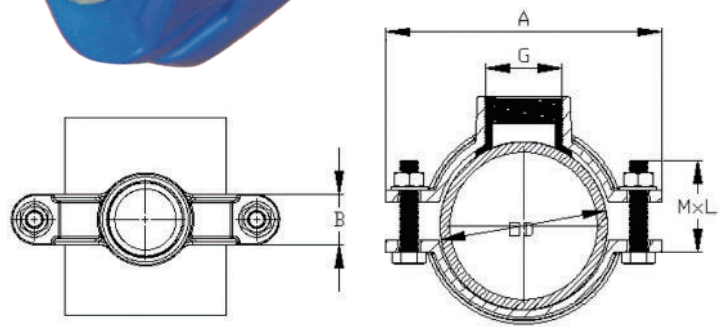

SIZE	A	B	G (Outlet Size)	OD	MxL
DN80	190	40	3/4"-2"	88-105	M14x70
DN100	210	40	3/4"-2 1/2"	108-128	M14x70
DN125	236	40	3/4"-3"	130-150	M14x70
DN150	266	40	3/4"-3"	159-180	M14x70
DN200	320	45	3/4"-3"	215-236	M14x70
DN250	372	45	3/4"-3"	266-288	M14x70
DN300	422	45	3/4"-3"	314-336	M14x70

- 1,Outlet thread must be sealing thread such as BSP, NPT, or CC. Threads without a sealing function (e.g., metric threads) are not suitable.
- 2,The standard length for sealing threads is typically 20mm. If customers have special requirements, we can extend the length.
- 3,In addition to the outlet sizes listed in the table above, we can also provide larger outlet sizes. However, this requires special design adjustments and mold modifications.

JUDBERD MACHINERY

WIDE RANGE SADDLE CLAMP STYLE WRSC 001



WIDE RANGE SADDLE CLAMP
STYLE WRSC 001

PIPE COMPATIBILITY

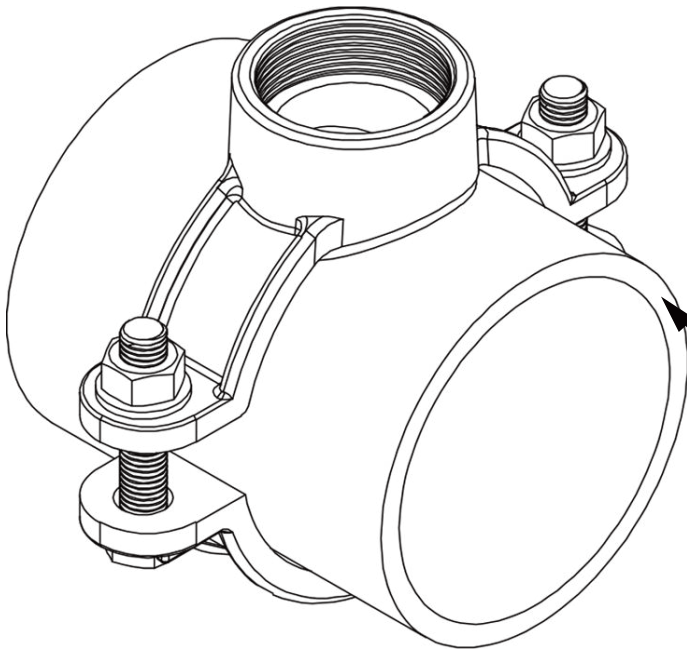

Steel, cast iron, asbestos cement, GRP etc which pipe OD is in our range
Not suitable for plastic pipe (PE & PVC pipe)

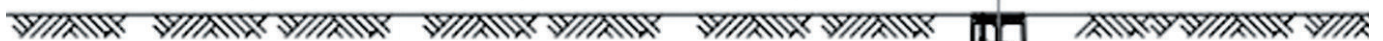

Isolation valve can be any valve with a shut-off function, such as a gate valve, ball valve, or service valve. However, it is essential to ensure that the male threads on the valve match the standard of the female threads on the outlet of the saddle clamp and that the threads have a sealing function.

The key dimensions of a saddle clamp consist of two parts:
1st is the material and outer diameter of the main pipe (as shown in Figure 1),
2nd is the standard and size of the threaded outlet for the branch (as shown in Figure 2).

